

SLAPO TYP 1 AC01

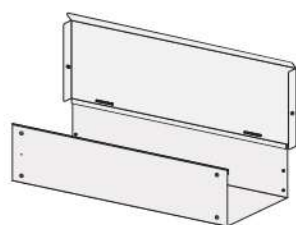

Ax1

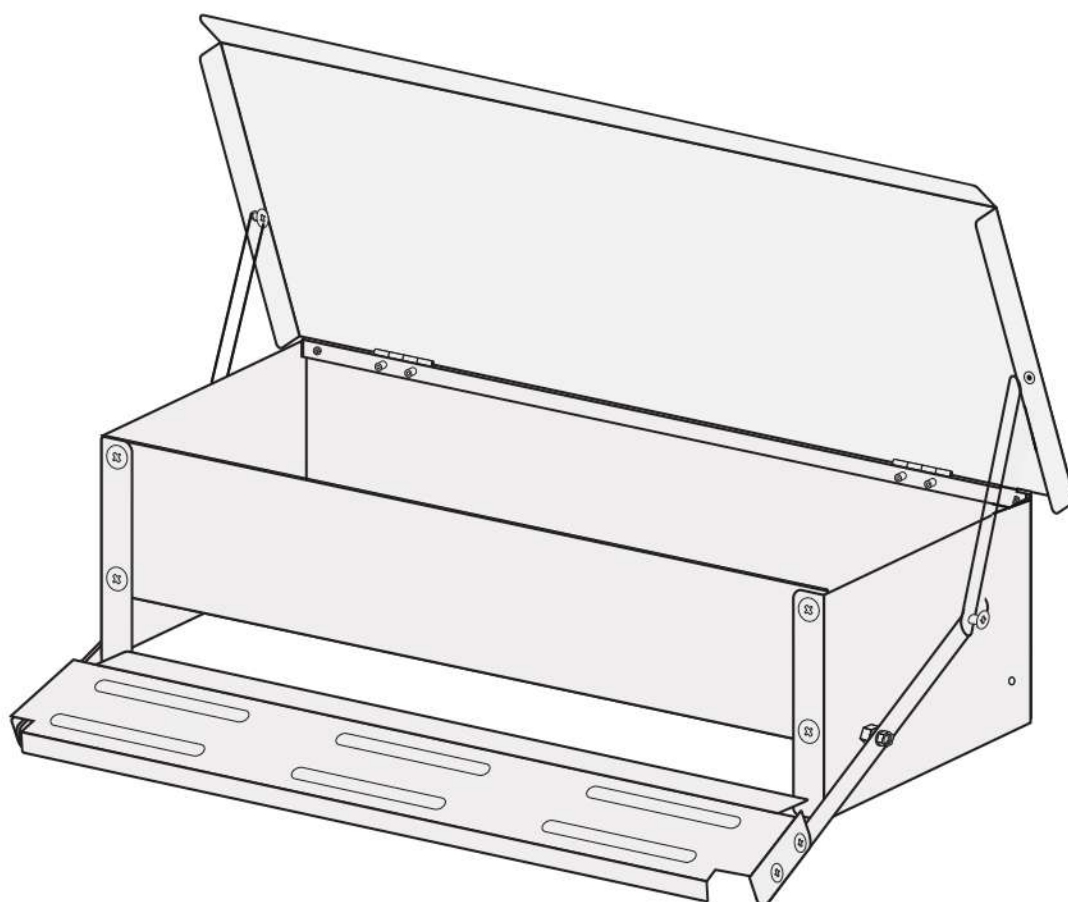
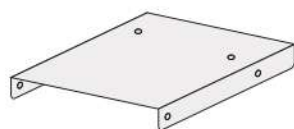

Bx2

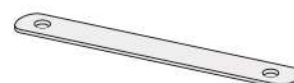

Dx2



Ex2

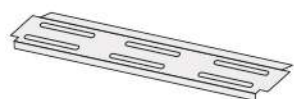

Fx1



M1x16

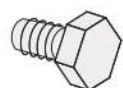

M2x2



M3x2



M4x2



M5x8

1

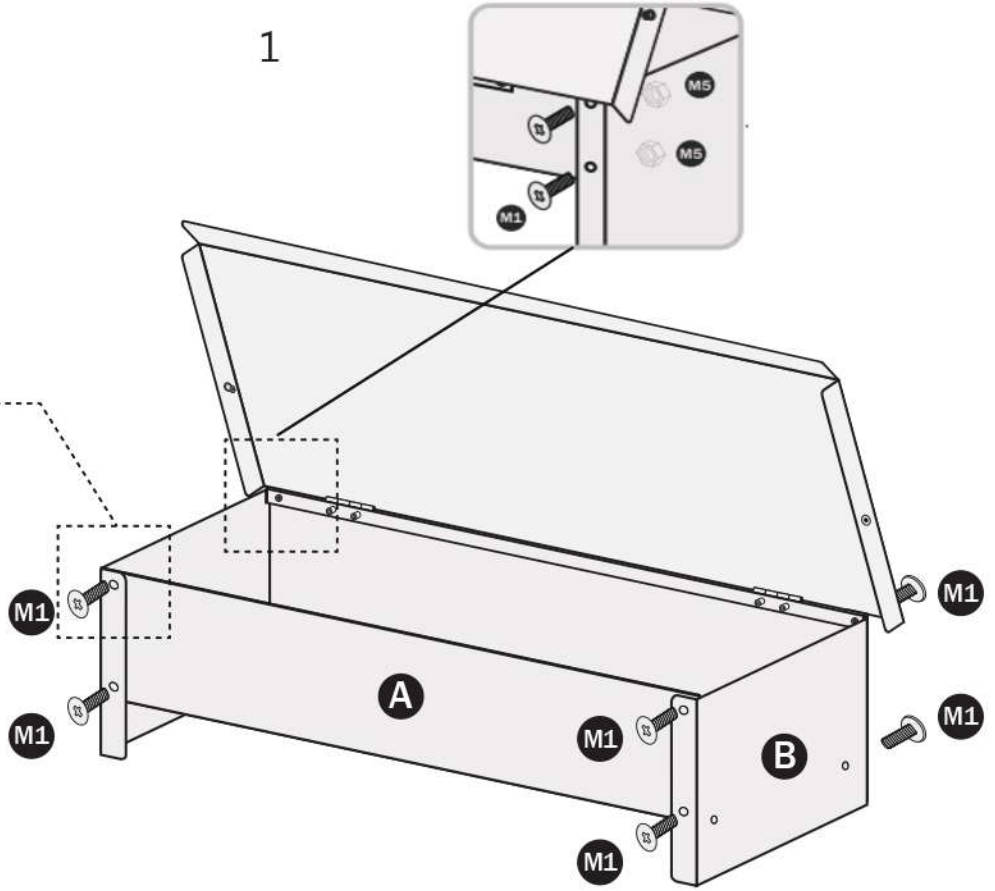
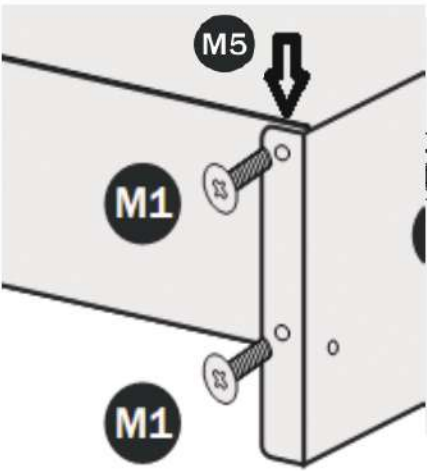
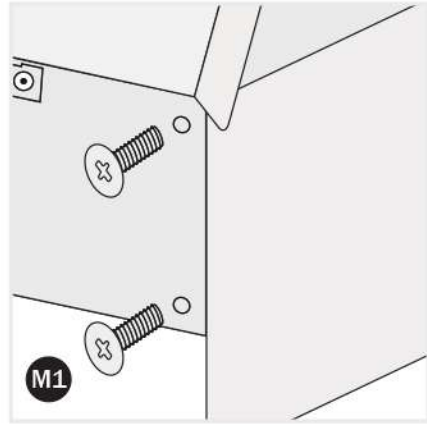

2

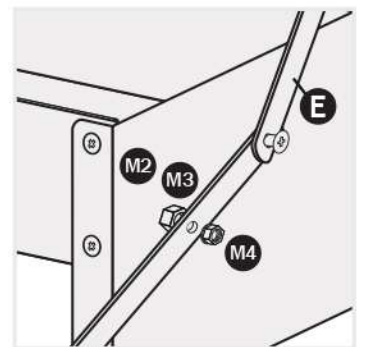
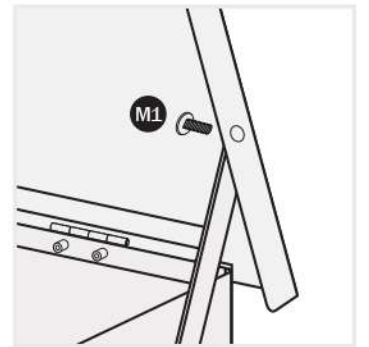
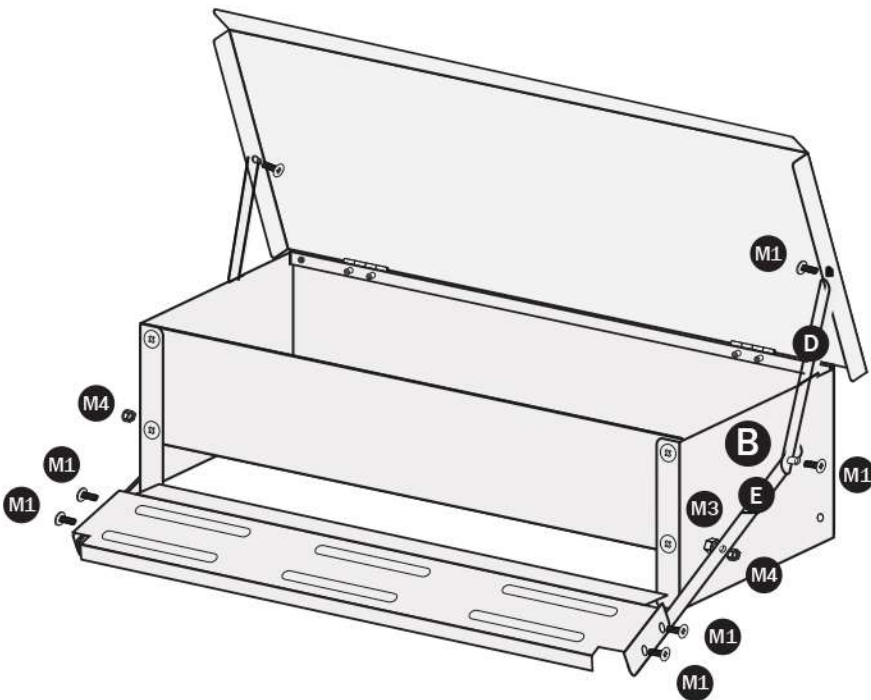

Notă: Vă rugăm să lăsați puțin spațiu între partea B & bara de fier E & șurubul M3 & șurubul M4 (M4 are opritor pe o parte pentru a evita ca șurubul să iasă afară, iar M4 este mai gros, care ar trebui pus afară)